

CST EM STUDIO LOW FREQUENCY ELECTROMAGNETIC DESIGN AND SIMULATION

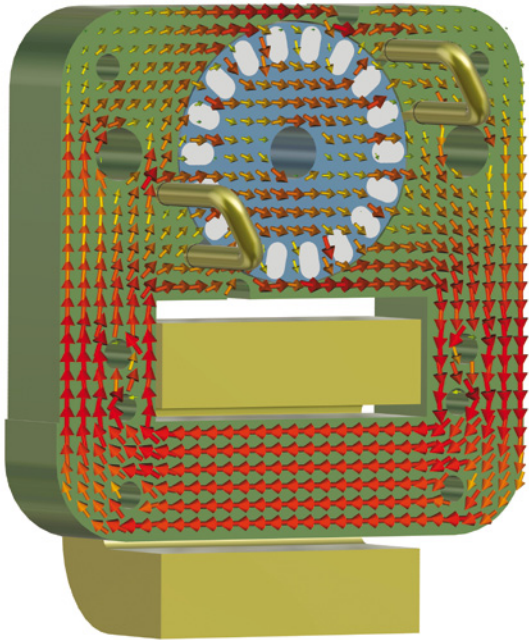

Magnetic flux density under no-load conditions for a shaded pole induction motor

CST STUDIO SUITE™ enables you to characterize, design and optimize electromagnetic devices before creating your first prototype. This can help save substantial costs especially for new or cutting edge products, reduce design risk, and improve overall performance and profitability.

CST STUDIO SUITE includes various solver modules that are ideally suited to the analysis of static and low frequency devices. CST EM STUDIO® (CST EMS) is dedicated to full 3D EM simulation in a wide application range, including sensors, circuit breakers, magnets and coils. Modules include static, quasi-static, full-wave, and transient electromagnetic field solvers. Additionally CST MPHYSICS STUDIO™ (CST MPS) enables thermal and mechanical stress analysis. CST STUDIO SUITE unites all solver modules in one user-friendly interface. This gives you the flexibility to choose the technology best suited to your application. Advanced design flow integration with mechanical tools, versatile post-processing capabilities and inbuilt automatic optimization schemes, make CST STUDIO SUITE an invaluable part of your toolbox.

APPLICATIONS

- Coil and magnet design
- Sensors and actuators, NDT
- Electromechanical devices
- Motors, generators and transformers
- Shielding
- Electrostatic and high voltage devices
- Biomedical applications
- Magnetic recording
- Induction heating

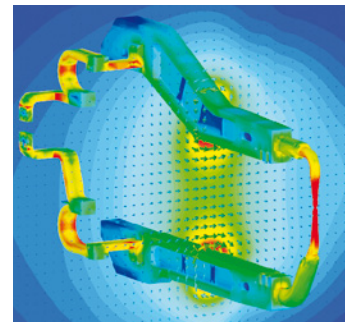

Current and magnetic flux density in a resistance spot welding gun at 50 Hz

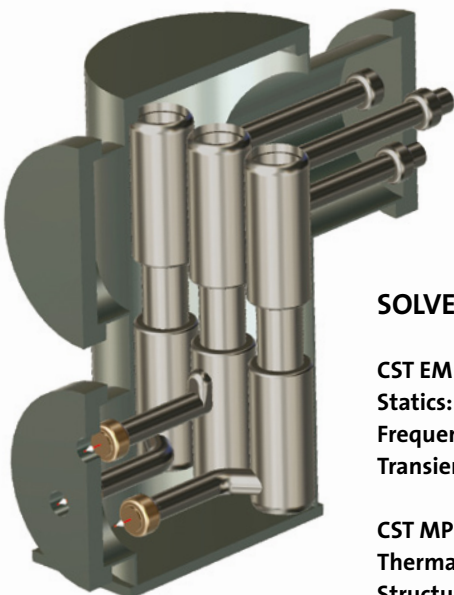

50 Hz gas-insulated switch

SOLVER MODULES

CST EM STUDIO®

Statics: electrostatic, magnetostatic and DC current

Frequency domain: electroquasistatic, magnetoquasistatic, full wave

Transient: magnetoquasistatic transient

CST MPHYSICS STUDIO™

Thermal: static and transient thermal

Structural mechanics: stress and deformation



CHANGING THE STANDARDS

STATIC AND LOW FREQUENCY ELECTROMAGNETIC DESIGN AND SIMULATION

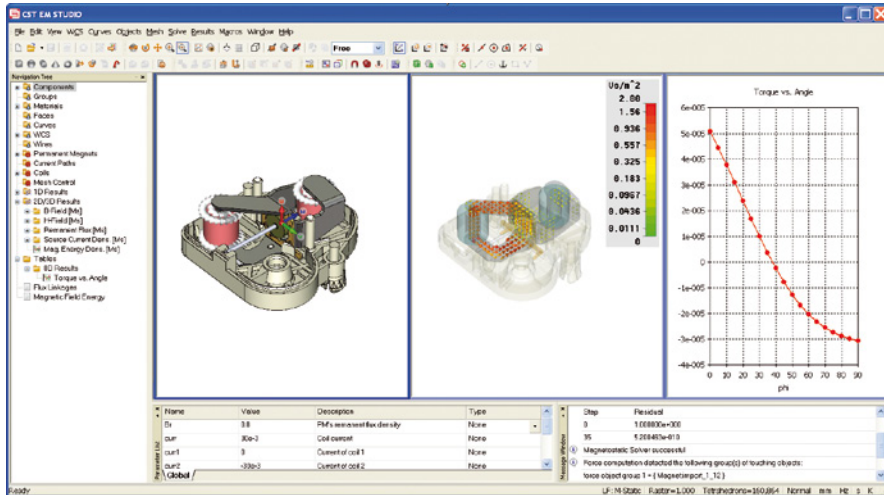

CST EMS graphical user interface showing the workflow for the magnetostatic simulation of a stepper motor with torque versus permanent magnet angle parameterisation results.

CST consistently promotes the best-in-class approach. We specialize in developing 3D EM software and provide straight-forward, easy-to-use links with other best-in-class vendors, connecting all available expertise. A wide range of import/export filters enable the easy exchange of geometrical data with CAD tools. Furthermore, imported structures can be modified and parameterized, and used for optimization and design studies.

Moreover the powerful VBA based and OLE-compatible macro language allows direct communication with programs such as MATLAB®.

SIMULATION WORKFLOW IN THE CST DESIGN ENVIRONMENT

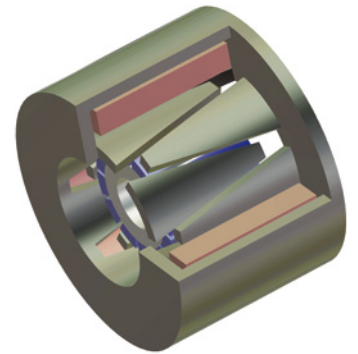
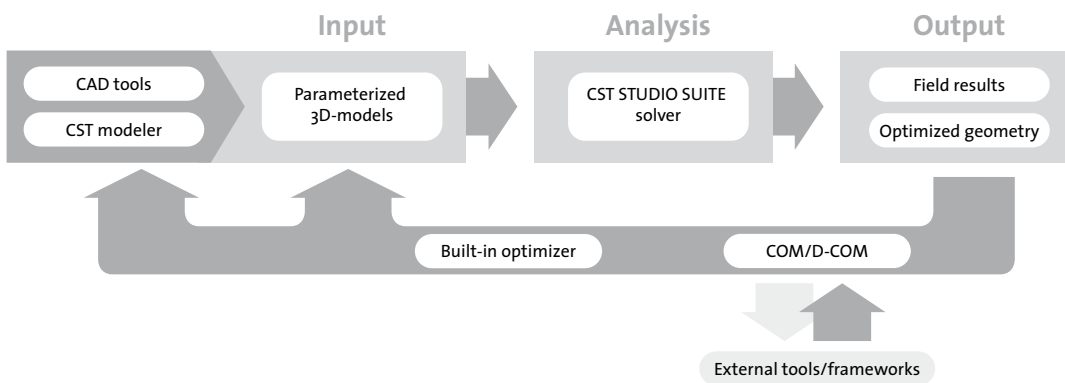

Model of a claw pole induction generator

KEY FEATURES

- Powerful, intuitive and easy-to-use user interface
- CAD import, automatic healing, structure modification, and export
- Tetrahedral and hexahedral mesh topologies
- State-of-the-art multi-grid solver technology with 2nd order elements for high accuracy
- Automatic adaptive mesh refinement
- Automatic extraction of secondary electromagnetic quantities
- Fully integrated optimization and parameterization modules
- Automatic calculation of force, torque, inductance and capacitance, flux linkage and induced coil voltages
- Potential and charge definition, voltage sources, coils and current paths, permanent magnets, nonlinear materials and current ports
- Electromagnetic power loss and force density export to CST MPS for thermal and structural mechanics simulation
- Magnetostatic co-simulation between CST EMS and CST MWS for ferrite simulations

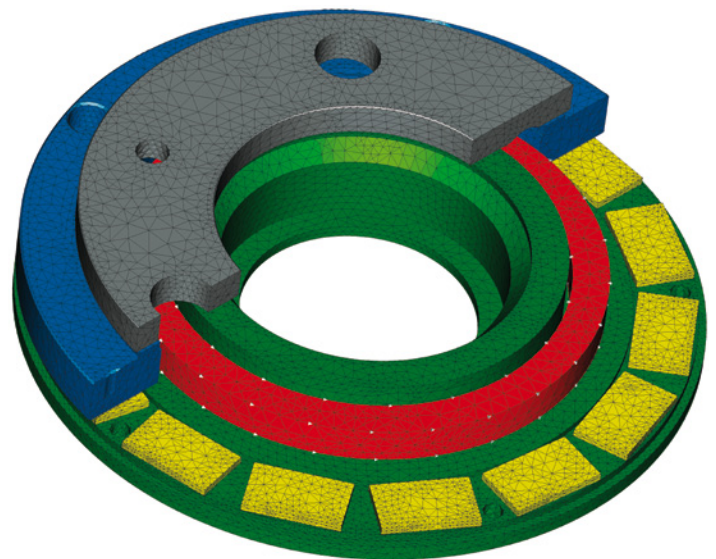

Automatic tetrahedral mesh generation in a magnetic brake